

COLLEGE OF SOUTHERN IDAHO
BOARD OF TRUSTEES

February 25, 2002

5:30 p.m.
TAYLOR BUILDING
ROOM 258

AGENDA

MINUTES: (A) *Mike Mason*

TREASURER'S REPORT: (A) *Mike Mason*

FY 2003 BUDGET HEARING : (A) *Mike Mason*

VISION AND FEEL SUMMER 2002: (A) *Mike Mason*

VISION AND FEEL FALL 2002: (A) *Mike Mason*

OPW PREVENTATIVE MAINTENANCE PROJECT BIDS: (A) *Mike Mason*

ADOPTION OF ASCSI SUBSTANCE ABUSE POLICY: (A) *Graydon Stanley & Wendy Lane*

SABBATICAL REPORT : (I) *Dennis Heiner*

TRAFFIC REPORT : (I) *Randy Dill*

OVER 60 & GETTING FIT FUNCTIONAL FITNESS STUDY: (I) *Jan Mittleider & Al Frost*

REVIEW DISTRICT 411-CSI AGREEMENT CONCERNING TECH CENTER: (I)
Present Meyerhoeffer

PRESIDENT'S REPORT: (I) *President Meyerhoeffer*

FY 2003 APPROPRIATIONS: (I) *President Meyerhoeffer*

FY 2003 BUDGET: (I) *President Meyerhoeffer*

OLD BUSINESS

NEW BUSINESS

COLLEGE OF SOUTHERN IDAHO
COMMUNITY COLLEGE DISTRICT
BOARD OF TRUSTEES MEETING
FEBRUARY 25, 2002

CALL TO ORDER: 5:30 p.m. PRESIDING: LeRoy Craig

ATTENDING: Trustees: LeRoy Craig, Dr. Charles Lehrman,
Donna Brizee, Bill Babcock and Dr. Thad Scholes

College Administration: Gerald Meyerhoeffer, President
John M. Mason, Secretary/Treasurer
Dr. Jerry Beck, Vice President of Instruction
Dr. Curtis Eaton, Vice President of Planning and
Development
Dr. DeVere Burton, Dean of Instruction
Dr. Ken Campbell, Dean of Technology

Graydon Stanley, Director of Student Information
Randy Dill, Physical Plant Director
~~Dr. Campbell, Director of Dual Credit~~
Karen Baumert, Public Information Director
Doug Maughan, Herrett Center/Public Information
Director

CSI Employees: Dennis Heiner, Jan Mittleider, Kathy
Deahl and Henry Jones

Visitors: Dr. Alan Frost, Wendy Lane and James Logan

Faculty Representatives: Rosemary Fornshell and Jim
Dawson

Times News: Robert Mayer

MINUTES OF THE REGULAR SESSION OF JANUARY 28, 2002, were
approved as written on MOTION by Dr. Thad Scholes.
Affirmative vote was unanimous.

TREASURER'S REPORT: The Treasurer's Report was approved on
MOTION by Bill Babcock. Affirmative vote was unanimous.

CSI Trustees

February 25, 2002

Page 2

PRESIDENT'S REPORT:

1. The Board approved a budget hearing date of August 19, 2002 on MOTION by Dr. Thad Scholes. Affirmative vote was unanimous.

the summer session of 2002 and the sessions of fiscal year 2003 from \$705.00 to \$775.00 for 10 credits, from \$1,250 to \$1,375 for Out of State and Foreign tuition and from \$35.25 per credit to \$46.50 for dual credit tuition and fees on MOTION by Dr. Charles Lehrman. The MOTION is contingent upon legislation passing that will allow us to increase tuition by 10% per year. Affirmative vote was unanimous.

3. Mike Mason and Randy Dill told the Board about two Division of Public Works projects being completed on campus. The first project is the replacement of the

the moving of Frontier Road by the Expo, crack sealing, seal

2002.

4. Graydon Stanley and Wendy Lane presented the Associated Students of the College of Southern Idaho Substance Abuse Policy to the Board. The plan involves four levels for infractions and corrective action. The policy will be a part of the student handbook. The policy will be approved

5. Dennis Heiner reviewed his sabbatical experiences working as a manager at a fly tying manufacturing business in Thailand. He felt the business experience was very

6. Jan Mittleider and Dr. Alan Frost presented the Over 60 and Getting Fit Functional Fitness Study. Dr. Frost noted that over seven hundred individuals were involved in the program between the ages of sixty and ninety-six. He reviewed various tests given ten weeks apart showing significant gains in strength and endurance by seniors in

CSI Trustees
February 25, 2002
Page 3

6. (continued) the program. Ms. Mittleider and Dr. Frost stressed that this program had a significant impact on the health of seniors in the Magic Valley. Participation was significant even though the program had not been marketed to health care providers. Grant funds will be sought to maintain and expand the program.

7. Randy Dill presented data concerning traffic counts of vehicles entering and exiting campus from Falls Avenue. The

8. The President reviewed the agreement with the Twin Falls School District regarding construction of a technical agreement on MOTION by Dr. Chad Scholes contingent upon

Affirmative vote was unanimous.

10. The President advised the Board that athletics lost a sport two years ago and that we had one less sport than required by the league. He also stated that we had fewer

percent in student numbers in the last ten years.

the Board for his extensive work in bringing Dell

Beck was the key person responsible for developing training, representing the college and serving as a liaison between Dell and the community.

CSI Trustees
February 25, 2002
Page 4

12. Mike Mason advised the Board that Mary Marshall of our Head Start program had been selected as the Head Start National Deputy Director of the Year. She will travel to Washington, D.C. to formally receive the award.

ADJOURNMENT was declared at 6:59 p.m.

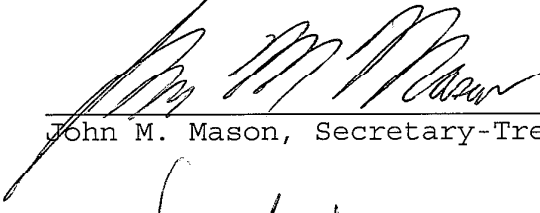

John M. Mason, Secretary-Treasurer

APPROVED March 18, 2002

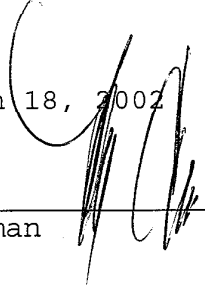

Chairman

COLLEGE OF SOUTHERN IDAHO

PROPOSED TUITION INCREASE FOR SUMMER OF FY 2002 AND FY 03

FEE DESCRIPTION	2001-02 DOLLARS 10 CREDITS	2002-03 DOLLARS 10 CREDITS	PERCENTAGE INCREASE
TUITION	350	385	10.00%
REGISTRATION SERVICES	70	100	42.86%
LAB & LIBRARY	75	80	6.67%
SPECIAL FEES	210	210	0.00%
TOTAL	705	775	9.93%
OUT OF STATE/FOREIGN	1,250	1,375	10.00%

DUAL CREDIT CLASSES WILL PAY 60% OF TUITION & FEES=\$46.50 PER CREDIT
 72.9% OF TUITION & FEES GO TO THE GENERAL FUND.

FY 02
 DUAL CREDIT 50% OF TUITION & FEES 35.25 PER CREDIT

FY 03
 DUAL CREDIT RATE - 60% 46.50 PER CREDIT

PROPOSED TUITION INCREASE FOR SUMMER OF FY 2002 AND FY 03



COLLEGE OF



IDAHO

February 20, 2002

To: President Meyerhoeffer and the College of Southern Idaho Board of Trustees

From: Mike Mason

Re: DPW Preventative Maintenance Projects

We opened bids for two Division of Public Works preventative maintenance projects over the last two weeks.

The first project was the fire lane replacement by the gym. This project involves the replacement of the fire lane and the construction of a turnaround circle large enough for the over the road 44 passenger buses. The estimated construction budget was \$50,000 and the low bidder was J Bar S of Twin Falls, Idaho in the amount of \$48,450. We hope to get this project completed prior to June 1, 2002.

The second project involves the construction of sidewalks from Falls Avenue into the campus along with completing the circle with interior sidewalks and a sidewalk to the Center for New Directions. The project also involves crack sealing and seal coating all major

the amount of \$262,637. The construction budget is

scheduled for completion prior to August 1, 2002.

In analyzing campus pavement during this project, it became apparent that we are going to have to begin a tightly scheduled program to maintain and replace pavement in existing parking lots. It was recommended that we chip seal the newer lots to preserve them and look at scheduling replacing pavement in several of the older lots. We will program.



315 Falls Avenue
P.O. Box 1238
Twin Falls, ID 83303
(208) 733-9554 ext. 2690
1-800-680-0274 (ID & NV Only)

IN THE SENATE

RESOLUTION #2

BY THE ASCSI SENATE
2001-2002

TO THE BOARD OF TRUSTEES OF THE COLLEGE OF SOUTHERN IDAHO
REGARDING THE ADOPTION OF THE SUBSTANCE ABUSE POLICY:

WHEREAS, we the sitting elected student representatives of the College of Southern Idaho

regarding matters of mutual importance,

WHEREAS, the College of Southern Idaho needs to take a stand regarding controlling the abuse and use of alcohol and all other forms of drugs,

WHEREAS, the College of Southern Idaho needs to provide a helpful and educational environment for all students struggling with any form of substance abuse,

WHEREAS, the College of Southern Idaho needs to provide a safe and protected educational and controlled social environment,

students regardless of positions, age, or involvement in school affairs.

NOW, THEREFORE BE IT RESOLVED BY THE ASCSI SENATE ACTING AS ELECTED REPRESENTATIVES OF THE STUDENTS OF THE COLLEGE OF SOUTHERN IDAHO GIVE THEIR FULL SUPPORT TO THIS ADOPTION OF THE PROPOSED POLICY.

Substance Abuse Policy for the College of Southern Idaho

Legal Provisions. Under Idaho law, it is illegal for any person under 21

possess, or consume beer, wine, or other alcoholic or intoxicating liquor. It is also illegal to sell, serve, give or furnish beer, wine, or other alcoholic or intoxicating liquor to a person under age specified above. It is also illegal for

accountant or for any person to permit another person to use any state identification document by and underage person to purchase alcoholic

beverages. Because CSI campus is within Twin Falls City limits, city

ordinances which conform closely to state law also apply on the

Policy. Alcoholic beverages may not be possessed or consumed under any circumstances on the CSI campus and at any CSI sponsored events held off of campus. Possession and consumption of alcohol in the dorms is prohibited. The use of drugs is strictly prohibited for use anywhere on campus or off campus at CSI sponsored events. Students who become

fall under CSI's drug and alcohol policy.

College's Role. CSI does not condone or remain indifferent to any act or

primary role in dealing with matters involving the use or potential use of drugs or alcohol by its students is that of prevention, counseling and education. The investigatory, prosecuting, and disciplinary roles relating to illegal drug and alcohol use are the responsibility of the college and law-enforcement authorities.

The following offenses and delinquency represent typical offenses that will most likely

Each incident is considered on its own merit, prior judicial background or other behavioral incidents will be taken into consideration when decisions are rendered. In some situations, a first offense may result in a more serious

Level 1

A level 1 offense is when a student violates the substance abuse policy. Student will be required to attend a 2-hour drug education seminar. An example of this violation may include, but is not limited to: possession of alcohol under age or sustained presence in a room where other alcohol policy violations are taking place.

Level 2

A level two offense is when a student violates the substance abuse policy for a second time or when a student's use of substances causes personal or property consequences. Depending on the situation the student will attend the 2-hour education seminar. Students will also be referred to counseling services, a 12-step program and a letter sent to their parents if under the age of 21. Examples of this violation include, but are not limited to: possession of marijuana, drug paraphernalia, large quantities of alcohol, kegs or beer balls, or use in public or common areas, participation in drinking games, or a repeat of a level one offense.

Level 3

A level three offense involves behavior that suggests the excessive consumption of alcohol or other drugs, or leads to an alcohol or other drug-related arrest. At this level, the student's parents will be notified, the student

individual circumstances. This level of severity may require that the student

students who are responsible for hosting or sponsoring drinking games, who procure kegs, or otherwise engage in sponsoring behavior, which is unsafe, by its nature are considered to be responsible for a level three offense.

Level 4

A level four offense is when substance use results in behavior that leads to potential or actual harm to self or others. The student will likely be suspended or separated from CSI and could face referral to the local law enforcement agency. Some examples might include, but are not limited to: growing, manufacturing, selling, or distributing illegal substances, selling or

Failure to Comply:

If students choose to not participate in the required activities relative to their violation of the drug and alcohol policy the student may be suspended from CSI.

Sample Letter and Policy
(Currently used at Florida State University)

Students under the age of 21 are subject to the parent/guardian notification

of the student and university.

Conditions under which parent/guardian will be notified:

1. As a rule, upon the finding of responsibility for the first alcohol or drug related offense. The student will be required to attend a 2-hour educational seminar.
2. Students, who violate level two, three or four of the substance abuse policy are subject to parental notification in either written or verbal form, if they are under the age of 21.
3. Student affairs administrators reserve the right to exercise professional judgment and discretion in the application of this policy.
4. Draft of the Letter to be sent to Parent/Guardian:

Dear:

As a result of our concern for your child's health, well-being, and success at College

{Insert name} has been sanctioned appropriately in accordance with the college's Code of Conduct.

I encourage you to have a discussion with your child about this incident. We, at The

the future, inappropriate behavior will not take place.

If, after speaking with your child, you want additional information about this policy, you may contact me at (208) 733-{Insert appropriate phone ext.}. Information about our policies can be found in The College of Southern Idaho's handbook or at

Sincerely,
{Name}
{Dean of Students Department or Director of University Housing}

SOUTH



Falls Avenue

EAST



(E)

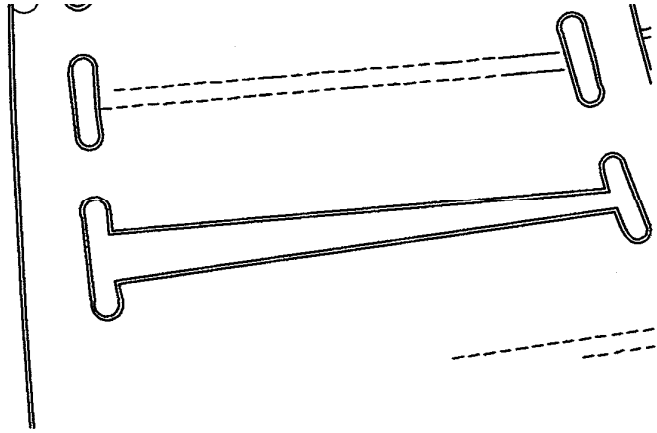

COLLEGE OF SOUTHERN IDAHO

Main Entrance

Falls Avenue

WEST

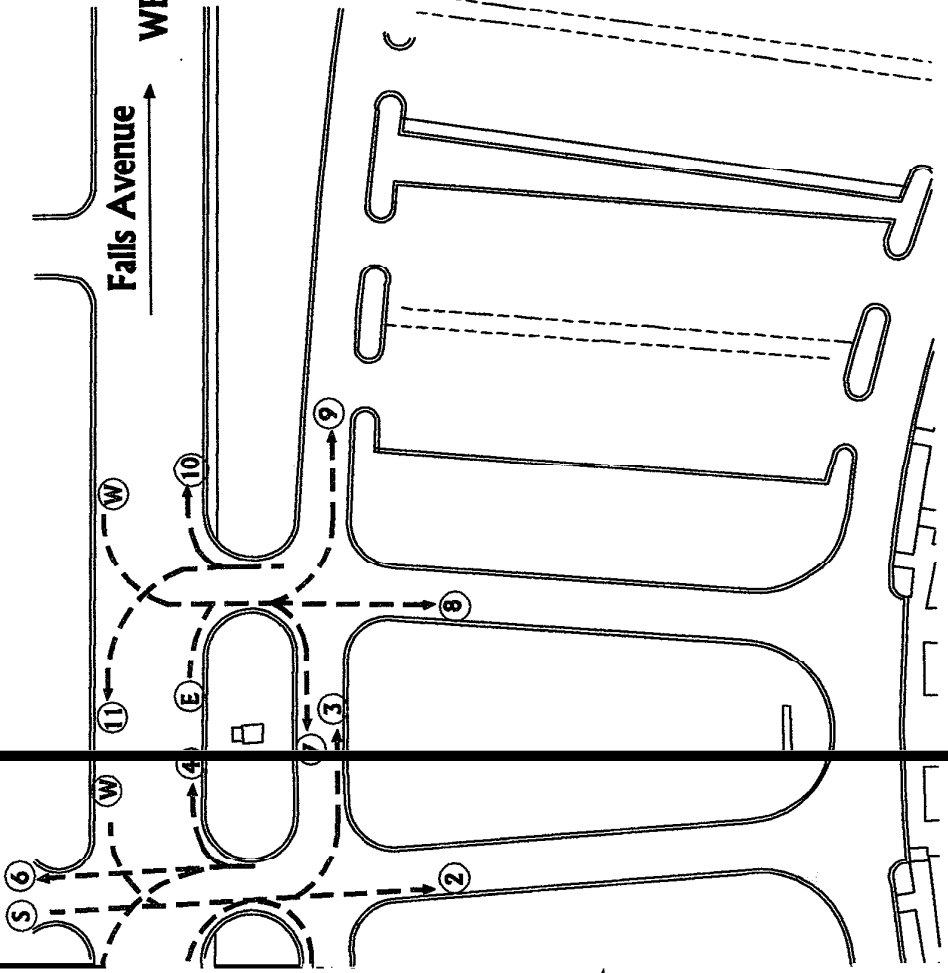

CSI February 20, 2002 Traffic Count

- Counted for a 9 hour period on a higher attendance day - Wednesday
- Counts were on 15 minute intervals to identify the busiest times of day
- Counted the number of cars making each possible maneuver (see map)
- Busiest 15 - 8:45 Second - 12:45 - Third - 11:45 - Fourth - 9:45 - Fifth - 1:45
- East Entry is busiest with 1880 entries and 965 exits
- West Entry had 822 entries and 1295 exits
- Trend looks like the majority enters at the east entry, and exits from the west entry
- Having said that, the east entry is still strong with 965 exits as well
- Total car maneuvers in and out over the 9 hour period - $4,962 = 551.3/\text{hr} = 137.8/15 \text{ min.}$
- Exits to the west number 663 from both entries
- Exits to the south number 49 from the east entry only
- Exits to the east number 1548 from both entries
- Most popular entry is E2 with 863
- Most popular exit is 11 with 856

Whenever Falls Avenue is busy and we have high volumes of east bound cars exiting from our campus entries, there are problems due to crossing westbound traffic to gain refuge in the median before easing into the second lane going east. Any south bound exits (which there are a few), or pedestrians crossing seem to complicate things even further.

Whenever there are cars backed up on the main campus arteries, attempting to exit campus, and simultaneously high volumes of automobiles are entering campus - attempting to cross traffic lanes immediately after entering (see maneuver 9) - a dangerous backup of traffic into the west bound lane of Falls can occur. Another problem that presented itself was when the same scenario mentioned earlier exists, and cars attempting to exit to Falls from the East parking lot attempt to cross the entering line of traffic from Falls (E,W or S 2)

Measurement input interval
5
6
7
8
9
10
11
12
13
14
15
16
17
18
19
20
21
22
23
24
25
26
27
28
29
30
31
32
33
34
35
36
37
38
39
40
41
42
43
44
45
46
47
48
49
50
51
52
53
54
55
56
57
58
59
60
61
62
63
64
65
66
67
68
69
70
71
72
73
74
75
76
77
78
79
80
81
82
83
84
85
86
87
88
89
90
91
92
93
94
95
96
97
98
99
100
101
102
103
104
105
106
107
108
109
110
111
112
113
114
115
116
117
118
119
120
121
122
123
124
125
126
127
128
129
130
131
132
133
134
135
136
137
138
139
140
141
142
143
144
145
146
147
148
149
150
151
152
153
154
155
156
157
158
159
160
161
162
163
164
165
166
167
168
169
170
171
172
173
174
175
176
177
178
179
180
181
182
183
184
185
186
187
188
189
190
191
192
193
194
195
196
197
198
199
200
201
202
203
204
205
206
207
208
209
210
211
212
213
214
215
216
217
218
219
220
221
222
223
224
225
226
227
228
229
230
231
232
233
234
235
236
237
238
239
240
241
242
243
244
245
246
247
248
249
250
251
252
253
254
255
256
257
258
259
260
261
262
263
264
265
266
267
268
269
270
271
272
273
274
275
276
277
278
279
280
281
282
283
284
285
286
287
288
289
290
291
292
293
294
295
296
297
298
299
300
301
302
303
304
305
306
307
308
309
310
311
312
313
314
315
316
317
318
319
320
321
322
323
324
325
326
327
328
329
330
331
332
333
334
335
336
337
338
339
340
341
342
343
344
345
346
347
348
349
350
351
352
353
354
355
356
357
358
359
360
361
362
363
364
365
366
367
368
369
370
371
372
373
374
375
376
377
378
379
380
381
382
383
384
385
386
387
388
389
390
391
392
393
394
395
396
397
398
399
400
401
402
403
404
405
406
407
408
409
410
411
412
413
414
415
416
417
418
419
420
421
422
423
424
425
426
427
428
429
430
431
432
433
434
435
436
437
438
439
440
441
442
443
444
445
446
447
448
449
450
451
452
453
454
455
456
457
458
459
460
461
462
463
464
465
466
467
468
469
470
471
472
473
474
475
476
477
478
479
480
481
482
483
484
485
486
487
488
489
490
491
492
493
494
495
496
497
498
499
500
501
502
503
504
505
506
507
508
509
510
511
512
513
514
515
516
517
518
519
520
521
522
523
524
525
526
527
528
529
530
531
532
533
534
535
536
537
538
539
540
541
542
543
544
545
546
547
548
549
550
551
552
553
554
555
556
557
558
559
560
561
562
563
564
565
566
567
568
569
570
571
572
573
574
575
576
577
578
579
580
581
582
583
584
585
586
587
588
589
590
591
592
593
594
595
596
597
598
599
600
601
602
603
604
605
606
607
608
609
610
611
612
613
614
615
616
617
618
619
620
621
622
623
624
625
626
627
628
629
630
631
632
633
634
635
636
637
638
639
640
641
642
643
644
645
646
647
648
649
650
651
652
653
654
655
656
657
658
659
660
661
662
663
664
665
666
667
668
669
670
671
672
673
674
675
676
677
678
679
680
681
682
683
684
685
686
687
688
689
690
691
692
693
694
695
696
697
698
699
700
701
702
703
704
705
706
707
708
709
710
711
712
713
714
715
716
717
718
719
720
721
722
723
724
725
726
727
728
729
730
731
732
733
734
735
736
737
738
739
740
741
742
743
744
745
746
747
748
749
750
751
752
753
754
755
756
757
758
759
760
761
762
763
764
765
766
767
768
769
770
771
772
773
774
775
776
777
778
779
780
781
782
783
784
785
786
787
788
789
790
791
792
793
794
795
796
797
798
799
800
801
802
803
804
805
806
807
808
809
810
811
812
813
814
815
816
817
818
819
820
821
822
823
824
825
826
827
828
829
830
831
832
833
834
835
836
837
838
839
840
841
842
843
844
845
846
847
848
849
850
851
852
853
854
855
856
857
858
859
860
861
862
863
864
865
866
867
868
869
870
871
872
873
874
875
876
877
878
879
880
881
882
883
884
885
886
887
888
889
890
891
892
893
894
895
896
897
898
899
900
901
902
903
904
905
906
907
908
909
910
911
912
913
914
915
916
917
918
919
920
921
922
923
924
925
926
927
928
929
930
931
932
933
934
935
936
937
938
939
940
941
942
943
944
945
946
947
948
949
950
951
952
953
954
955
956
957
958
959

LETTER OF UNDERSTANDING
BETWEEN

IDAHO BOARD OF TRUSTEES

PROFESSIONAL TECHNICAL CENTER OPERATION

There have been a number of concerns registered about the duties and responsibilities of the parties involved in the construction and operation of the secondary school Regional Professional-Technical Center located at the College of Southern Idaho. This letter of agreement is an attempt to outline the resolution of some of these concerns.

Program Designation

The Twin Falls School District plans to transfer the following programs from Twin Falls High School to the Professional-Technical Center in the fall of 2003, when the center opens: a) Information Technology, to include software and hardware applications; b) Agriculture Technology; and c) Health Services. These programs will be enhanced during the 2002-2003 school year via cooperation and coordination between TFSD and

College of Southern Idaho will provide in-kind assistance. A key outcome will be to assure a curriculum that results in student certification in at least one career path area

TFSD will also include sections of English and mathematics at the site in an effort to integrate academic components with technical components in a fashion similar to that of

will create subsequent programs from the areas of Automotive Technology, Electronics, Pre/General Engineering and Industrial Technology, depending upon local needs assessment results and student interest information. Funds for these programs' equipment needs will come from the successful bond issue, district school plant & facility levy, and grants.

The Twin Falls School District will take the lead role in development of secondary programs and curriculum as required under the role and mission of local school districts in coordination with industry experts, CSI instructors and administration. The College of Southern Idaho Technical Division will collaborate with TFSD faculty as appropriate

college and TFSD faculties will develop a planning process to address instruction in the

program of information technology, agriculture technology, health services, English and mathematics with the expectation that the curriculum and instruction in these areas will

industry standards and that incorporate in grades 11-12 the academic standards

The planning process will also include components that assure the optimal use of expensive equipment by secondary and post-secondary students and limits or precludes

assure the optimal movement of students through the curriculum according to their abilities and not necessarily their chronological age or grade level. Faculty at the College of Southern Idaho will collaborate in the development of new curriculum and programs. They will also work with secondary faculty to assure that curriculum is aligned between the secondary and post-secondary programs to allow for a natural transition of students

will collaborate with district committees to identify and develop new programs that may include but are not limited to automotive technology, engineering, drafting, etc.

Regional Commitment

The Twin Falls School District Board of Trustees is committed to providing technical-professional program offerings to not only students of the Twin Falls School District, but also to students in districts within the Magic Valley area. As evidence of this commitment, the TFSD Board of Trustees is willing to allocate up to 30% of its program space to districts throughout the region that are willing to participate in the programs and in sharing the costs of program operations. The TFSD Board will set aside "seats" within

districts that allow students to attend the Technical Center Program and cover

portion of student program costs not covered by HB510 funding and/or c) exchange

It is anticipated that the costs of the technical center program operation will be sufficiently covered by a combination of ADA, HB510 funds, and the other state/federal vocational technical funds that are available. The Twin Falls School District will also be

Occupations, will have a distance learning component that will provide program services using distance delivery to districts that have students participating in the program on the CSI campus and to districts that have students who participate from their home school only.

The Twin Falls School District Board will request involvement, participation, and commitment from school districts in the area immediately via a letter inviting said involvement and via a presentation at the Region 4 Superintendents' Association meeting

in December. Districts that agree to participate will be invited to have a role in the program development as it evolves by sending representatives to the program planning sessions outlined in the aforementioned section.

The TFSD will also be amenable to providing a location for ARTEC administration within the technical center facility.

The College of Southern Idaho will provide limited access for TFSD technical center programs to its wide area network and to its microwave broadcasting system in an effort to enhance the delivery of programs using advanced technologies. Any connection with the college system that compromises the college network will be removed. Access to the CSI network will be made available at times when it does not conflict with the CSI primary role of delivering college courses to its service area. The cost of providing technical support from one high school to another will be assessed at actual cost to the TFSD. CSI will also allow a connection between its wide area network and the TFSD wide area network so that TFSD and the technical center can remain associated with one another. In the event that expenses are incurred, fees will be for actual costs. CSI and

ARTEC Involvement

The TFSD Board of Trustees will continue its involvement in the ARTEC Consortium as long as the consortium remains a viable entity in the region; i.e., as long as a significant number of Magic Valley Districts participate financially in ARTEC. Once TFSD's portion of financial support for ARTEC extends beyond 25% of the locally generated funds needed to operate ARTEC, the district's involvement in the consortium will need to be annually approved by the TFSD board. Currently, ARTEC provides its members with coordination services, curriculum alignment services, professional development services, and telecommunications services/equipment. The TFSD will avail itself of

ARTEC-Net at the regional technical center. TFSD will also work within ARTEC to

develop funding proposals for regional academies to be submitted to grant agencies and foundations; e.g., Albertsons' Foundation.

Facility Construction Logistics

The TFSD Board of Trustees proposes to construct a facility of approximately 60,000 square feet to house current and future technical programs for secondary students in the Twin Falls School District and Magic Valley. The proposed site location is undeveloped acreage immediately North of the Herrett Center bordering North College Road, immediately East of the East access road depicted in the CSI Master Campus Plan. The TFSD will submit a \$7,000,000 bond issue question to the public in late February or early March of 2002, the purpose of which will be to pay for this construction and equipment.

As part of the construction project, TFSD will provide the infrastructure needed to accommodate a new facility on an undeveloped plat of land; that being, attachment to

gutter along the length of the project area and will pipe and cover the ditch that runs

The College of Southern Idaho will lease the property upon which the technical center is situated to TFSD for \$1 per year for the next 99 years. CSI will be responsible for any sewer and water upgrades required to meet the needs of other college facilities being planned in the future for the area around the technical center. CSI will also be responsible to pipe and fill the length of culvert along North College that extends beyond the limits of the technical center. CSI will also be responsible for creating sidewalks, curbs, gutters,

designated by their master plan. Finally, CSI will be responsible for any requirements imposed by the city of Twin Falls for a thoroughfare through CSI property as designated.

College of Southern Idaho.

Amendment of Agreement

The terms and conditions of this agreement can be amended at any time by a majority extended in the same manner.

SCHOOL DISTRICT #411
Twin Falls, Idaho

COLLEGE OF SOUTHERN IDAHO
Twin Falls, Idaho

Chairperson